

Annual Examinations for Primary Schools 2014

---

YEAR 5	MATHEMATICS MENTAL PAPER	TIME: 15 minutes
--------	--------------------------	------------------

---

Teacher's Paper

Guidelines for the conduct of the Mathematics Examination – Mental Paper

1. Words written in **bold** should be **emphasised**.
2. Read, **loudly and clearly**, each question twice in succession, and then allow 5, to 10, to 20 seconds as the test progresses through the three sections.
3. Access to rough paper for working out answers is **not allowed**. Any working on the answer sheet, however, will not be penalised.
4. The questions should be read out in **English** and **no code-switching/mixing is allowed**. Code-switching is permitted **only** for giving pupils instructions.
5. Before starting the test, read out the following instructions, using **exactly these words**:
  - *I will read out each question twice. Listen carefully both times. You will then have time to work your answer.*  
*Se naqralk kull mistoqsija darbtejn wara xulxin. Ismagħni sew. Wara jkollok il-ħin biex twegibha.*
  - *If you make a mistake, cross out the wrong answer and write the correct answer next to it.*  
*Jekk tieħu żball f'xi risposta, aqtagħha u ikteb ir-risposta t-tajba hdejha.*
  - *You will not be allowed to ask any questions once the test has started.*  
*Ma tistax tistaqsi mistoqsijiet hekk kif jibda t-test.*
6. At the end of the test, read out the following instructions, **using exactly these words**:
  - *The test is finished; put down your pens.*  
*It-test spicċa; poġġi l-bajrow fuq il-mejda.*

**MENTAL PAPER**

*'For this group of questions, you will have 5 seconds to work out each answer and write it down.'*

*'Għal dawn il-mistoqsijiet li ġejjin, għandek 5 sekondi biex taħseb u tikteb kull risposta.'*

1	How many hours in one day?
2	How many lines of symmetry in a square?
3	How many edges in a cylinder?
4	What is seven times nine?
5	Write one thousand and thirty in figures.

*'For the next group of questions, you will have 10 seconds to work out each answer and write it down.'*

*'Għal dawn il-mistoqsijiet li ġejjin, għandek 10 sekondi biex taħseb u tikteb kull risposta.'*

6	Write zero point seven as a fraction.
7	Which of these numbers is a multiple of eight: thirty eight, forty four or sixty four?
8	Round six hundred twenty three to the nearest ten.
9	What is one third of sixty?
10	How many centimetres in fifteen metres?

11	What is the <b>next odd number</b> after <b>ninety nine</b> ?
12	How many <b>grams</b> must you <b>add</b> to <b>two hundred and fifty grams</b> to make <b>half a kilogram</b> ?
13	What time is it <b>ten hours after six am</b> ?
14	How many <b>twenties</b> in <b>four hundred</b> ?
15	Write <b>one whole and one half</b> as an <b>improper fraction</b> .

*'For this group of questions, you will have 20 seconds to work out each answer and write it down.'*

*'Għal dawn il-mistoqsijiet li ġejjin, għandek 20 sekonda biex taħseb u tikteb kull risposta.'*

16	What is <b>three quarters</b> of <b>twelve euro</b> ?
17	I think of a <b>number</b> . When I <b>divide</b> the <b>number</b> by <b>six</b> , the <b>answer</b> is <b>three remainder five</b> . What is the <b>number</b> ?
18	How many <b>right angles</b> in a <b>clockwise turn</b> from <b>South East</b> to <b>North West</b> ?
19	<b>Subtract</b> <b>four hundred and ninety nine</b> from <b>six hundred</b> .
20	What is <b>twelve</b> multiplied by <b>eleven</b> ?

**END OF MENTAL PAPER**

**Annual Examinations for Primary Schools 2014**

---

**YEAR 5**

**MATHEMATICS MENTAL PAPER**

**TIME: 15 minutes**

---

**Name:** \_\_\_\_\_ **Class:** \_\_\_\_\_

### **Instructions to Candidates**

- The teacher will read each question twice. Listen carefully to the teacher both times. You will then have time to work your answer.
- If you make a mistake, cross out the wrong answer and write the correct answer next to it.
- You will not be allowed to ask any questions once the test has started.
- This paper carries a total of 20 marks.

**MENTAL PAPER  
ANSWER SHEET**

<b>1.</b>	<b>hours</b>
-----------	--------------

<b>2.</b>	<b>lines of symmetry</b>
-----------	--------------------------

<b>3.</b>	<b>edges</b>
-----------	--------------

<b>4.</b>	
-----------	--

<b>5.</b>	
-----------	--

<b>6.</b>	
-----------	--

<b>7.</b>	
-----------	--

<b>8.</b>	
-----------	--

<b>9.</b>	
-----------	--

<b>10.</b>	<b>cm</b>
------------	-----------

11.

12.

grams

13.

4:00 pm     6:00 pm

14.

15.

16.

€

17.

18.

right angles

19.

20.

DIRECTORATE FOR QUALITY AND STANDARDS IN EDUCATION  
Department of Curriculum Management  
Educational Assessment Unit

Annual Examinations for Primary Schools 2014

YEAR 5

MATHEMATICS  
WRITTEN PAPER

TIME: 1 h 15 min

Name: \_\_\_\_\_ Class: \_\_\_\_\_

1. Fill in:

a)	$65 + \square = 120$
b)	$409 - 98 = \square$
c)	$100 \div 4 = \square$
d)	$8 \times 70 = \square$
e)	Write the <b>next two numbers</b> in this sequence. 1, 2, 4, 8, 16, $\square$ , $\square$
f)	Fill in with a <b>square number</b> . $50 < \square < 100$
g)	$8.4 + \square = 10$
h)	$\text{€}15 \div 2 = \square \text{ c}$

i)	3 hours 15 minutes = <input type="text"/> minutes
j)	<p>Write these lengths in order, starting with the shortest.</p> <div style="display: flex; justify-content: space-around; align-items: center;"> <div style="border: 1px solid black; padding: 5px; text-align: center;"><math>\frac{1}{4}</math> m</div> <div style="border: 1px solid black; padding: 5px; text-align: center;">2.5 cm</div> <div style="border: 1px solid black; padding: 5px; text-align: center;">30 cm</div> <div style="border: 1px solid black; padding: 5px; text-align: center;">30 mm</div> </div> <div style="display: flex; justify-content: space-around; margin-top: 20px;"> <div style="border: 1px solid black; width: 60px; height: 40px; border-radius: 10px;"></div> <div style="border: 1px solid black; width: 60px; height: 40px; border-radius: 10px;"></div> <div style="border: 1px solid black; width: 60px; height: 40px; border-radius: 10px;"></div> <div style="border: 1px solid black; width: 60px; height: 40px; border-radius: 10px;"></div> </div> <div style="display: flex; justify-content: space-between; margin-top: 5px;"> <span>smallest</span> <span>largest</span> </div>

2. Circle the numbers that give 700 when rounded to the nearest 100.

<b>620</b>	<b>690</b>
<b>760</b>	<b>710</b>

3. Shade  $\frac{3}{4}$  of the shapes below.

a.

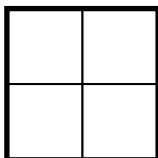

b.

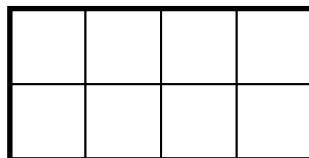

c.

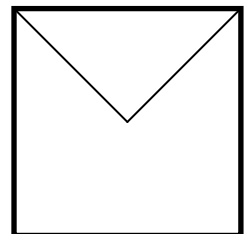



Name: \_\_\_\_\_ Class: \_\_\_\_\_

4. Complete the table.

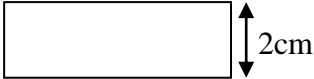
		Perimeter	Area
a.	square 	20 cm	
b.	rectangle 		12cm <sup>2</sup>

5. Here are eight number cards.

*Note:* You can use each number **ONLY ONCE**.



a. the largest 3-digit number you can make

--	--	--

b. a multiple of 7 and 9

--	--

c. a factor of 15 and 20

--

d. an even number

--	--

6. **60 children** chose their favourite flavour of yoghurt.  
The table shows the results.

Flavours of yoghurt	plain	strawberry	banana	lemon	apple
Number of children	8	16	18	4	14

- a. This bar chart shows the information from the table.

Fill in all the missing information on the vertical scale.

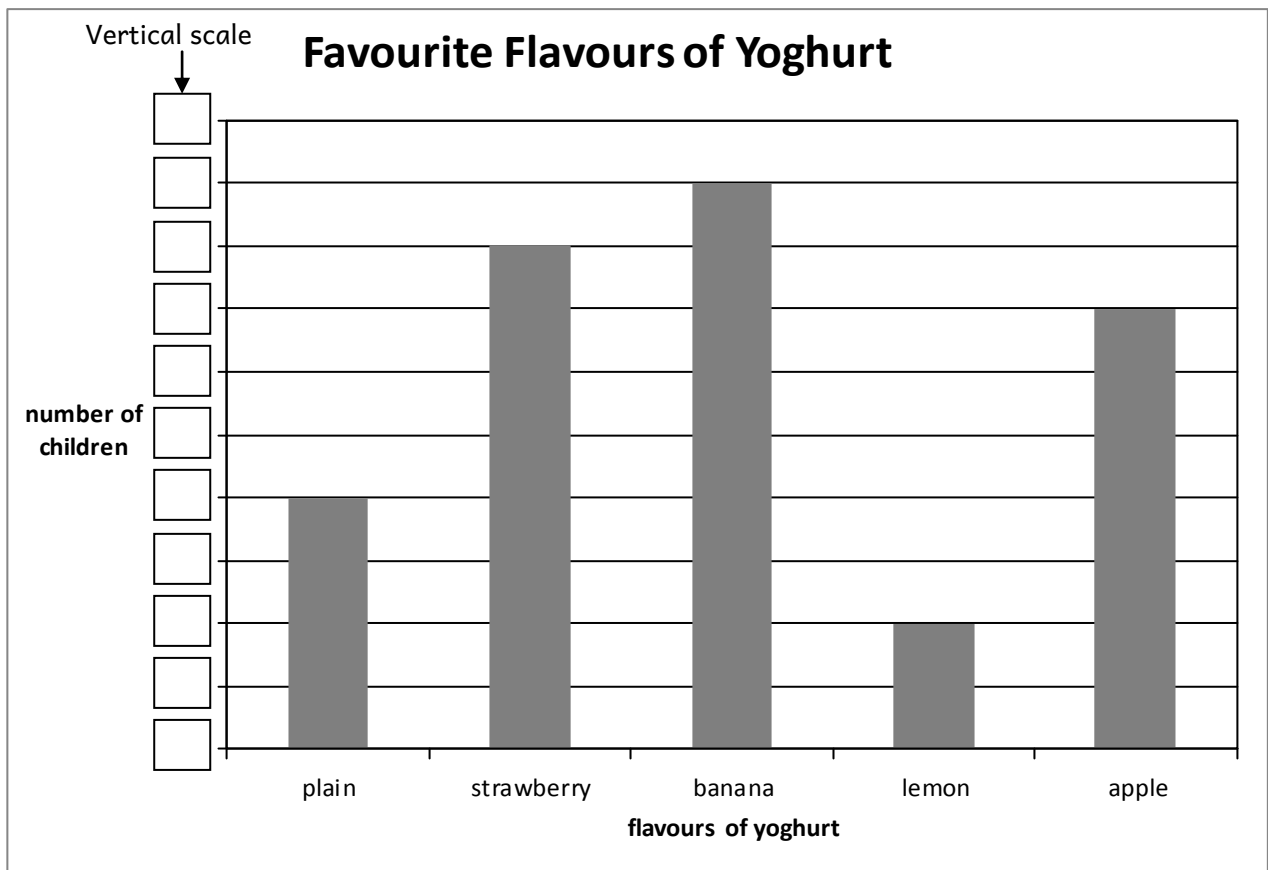

- b. Half of the number of children who like plain yoghurt, like:

Tick (✓) the correct answer.

strawberry

banana

lemon

apple

7. A shop sells bags.  
Here are four bags in the shop.



A  
€19.90



B  
€18.50

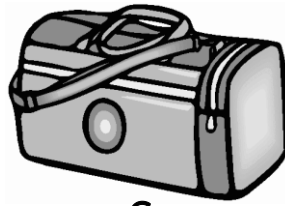

C  
€25.65



D  
€22.30

- a. How much does **Bag C** cost to the nearest Euro?

€ \_\_\_\_\_

- b. Elisa buys **Bag A** and **Bag B**.

She pays with a €50 note.



How much **change**, in Euro, does Elisa get?

Show your  
working here  
if needed.

Blank area for showing working.

€ \_\_\_\_\_

Name: \_\_\_\_\_

Class: \_\_\_\_\_

8. Fill in to make a correct calculation.

--	--







 × 

--	--

 = 

		5
--	--	---

Show your working here if needed.

9. This watermelon  weighs  $2\frac{3}{4}$  kg.  
The same watermelon  and 2 pears   weigh 3.08 kg.  
One of the pears  weighs 168 g.  
What is the weight of the other pear  in grams?

Show your working here if needed.

\_\_\_\_\_ g

10. Karl and Isabella are cyclists.

a. Last Sunday Karl drank:

400 *ml* of water between 6:00 and 8:00

350 *ml* of water between 8:00 and 10:00

940 *ml* of water during the bike ride between 10:00 and 12:00



How much water, in litres (*ℓ*), did Karl drink from 6:00 to 12:00?

Show your  
working here  
if needed.

\_\_\_\_ *ℓ*

b. The arrow on the scale shows the amount of water Isabella drank last Sunday from 6:00 to 12:00.

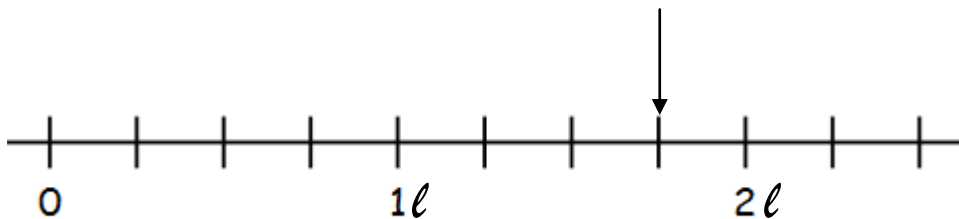

How much water, in litres (*ℓ*), did Isabella drink?

\_\_\_\_ *ℓ*

11. Look carefully at the grid below.

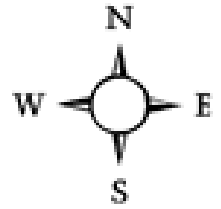

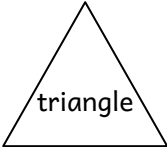
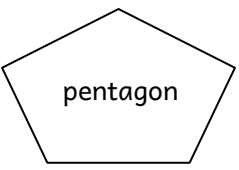
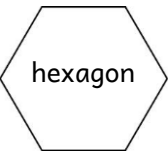
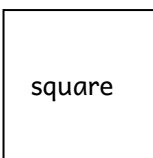
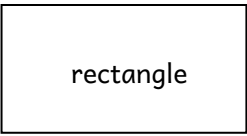
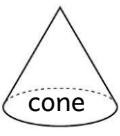
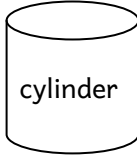
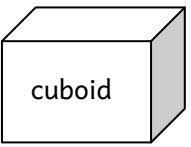
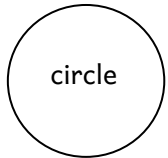
 triangle	 pentagon	 hexagon
 square	 rectangle	 cone
 cylinder	 cuboid	 circle

a) Tick (✓) the correct shape.

i) The **rectangle** is **SE** of the:

triangle

circle

cylinder

ii) The **cuboid** is **W** of the:

cone

circle

cylinder

iii) The **square** is **N** of the:

triangle

cuboid

cylinder

iv) The **pentagon** is **E** of the:

triangle

cuboid

hexagon

b. Fill in with the correct direction.

i) The **hexagon** is  of the **rectangle**.

ii) The **square** is  of the **pentagon**.



12. Below are the Opening Times of the **Splash Park**.

Monday to Friday	8:30 am	to	5:30 pm
Saturday	9:00 am	to	9:00 pm
Sunday	10:00 am	to	9:00 pm

a. For how long, in hours, is the Splash Park open on **Mondays**?

\_\_\_\_\_ hours

b. Tick (✓) the day on which the Splash Park is open for the longest time?

Tuesday

Saturday

Sunday

c. Emma went to the Splash Pool on **Wednesday**.

i) She was there at **quarter to 9**.

Show this time with an arrow ( ↓ ) on the timeline below.

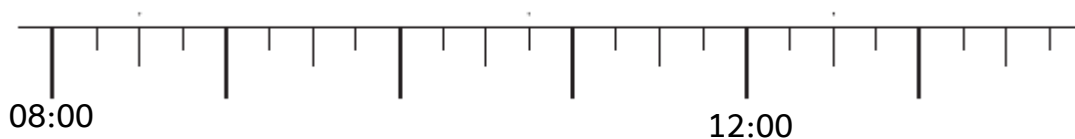

ii) Emma went back home **one hour before closing time**.

Show this time on the clock face.

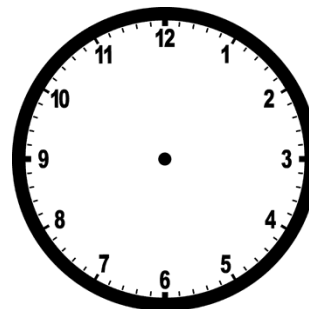

13. Stars Cup 2014 flags are placed along a straight path.

The **distance** between **2 flags** is **35cm**.

The path is **3.5 m long**.

A flag is placed at the start and another flag is placed at the end of the path.

How many **flags** are there?

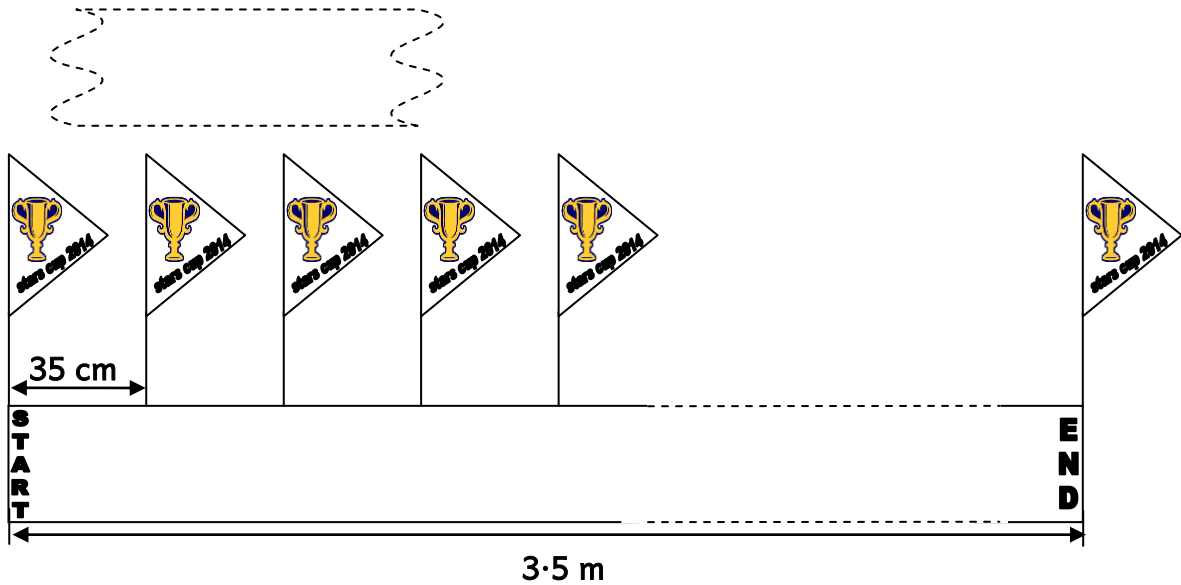

Show your working here if needed.

\_\_\_\_\_ flags

END OF PAPER



<b>Marks' Scheme</b>	<b>Nos.</b>	1 a - j	$10 \times 2$	=	20
		2 - 7	$6 \times 4$	=	24
		8 - 13	$6 \times 6$	=	36
			<b>TOTAL</b>		<b>80</b>